User Manual Supplement for the

SunScan System

Radio Link

type **SS1-RL4**



SS1RL-UM-3.1

AT

Delta-T Devices Ltd

Notices

Copyright

All rights reserved. Under the copyright laws, this manual may not be copied, in whole or in part, without the written consent of Delta-T Devices Ltd. Under the law, copying includes translation into another language.

Copyright © 2013 Delta-T Devices Limited

BF2, BF3 and BF5 Sunshine Sensor optics design and theory are Copyright © 1996 John Wood, Peak Design & Development, Winster, Derbyshire, U.K. and protected by Patent Nos: 1012633 (EU), 6417500 (US).

Trademarks

Windows is a registered trademark of Microsoft Corporation. All other trademarks are acknowledged. Some names referred to are registered trademarks.

CE Conformity

For a copy of EMC compliance certificates contact Delta-T at www.delta-t.co.uk or e-mail: tech.support@delta-t.co.uk

Warnings

To maintain conformance to CE standards, the equipment must be used as described in this supplement and in the SunScan Canopy Analysis System user manual. Modifications to the equipment may invalidate CE certifications.

Delta-T Devices Ltd reserves the right to change the designs and specifications of its products at any time without prior notice.

Authors

John Wood, Edmund Potter, Nick Webb.

User Manual Version: 3.1

Oct 2014

Delta-T Devices Ltd
130 Low Road, Burwell
Cambridge CB25 0EJ
U.K.

Tel: +44 (0)1638 742922
Fax: +44 (0)1638 743155
email: sales@delta-t.co.uk
web: <http://www.delta-t.co.uk>

Contents

Introduction	5
The SunScan System Radio Link	5
Achievable Range	6
About this Manual	6
Other Documents Required	6
Upgrade Systems	6
Unpacking	7
Components	7
Health and Safety Issues	8
Description	8
SunScan Probe	8
Transmitter Module	9
Getting Started	10
Familiarisation	10
Preliminary Checks	10
Transmitter Module and BF5	10
SunScan Probe	11
Testing the Range	11
Field Techniques	13
Measurement Procedures	13
Initial Considerations	13
Locating the BF5 Sensor	13
Field Calibration Check	13
Optimising the Range	14
Trees and Tall Canopies	14
Technical Reference	16
Specifications	16
Radio Link Performance	16
Range Disclaimer	16
SunScan Transmitter Module type BF-RL4	16
SunScan Radio Probe type SS1-RL4	16
Tripod Mounting Plate for BF5 and BF-RL4	17
Routine Maintenance	17
Batteries	17
Desiccant	18

Warranty and Service	19
Terms and Conditions of Sale	19
Service and Spares	20
Technical Support	20
Contact Details:	20
Troubleshooting	21
Procedure	21
BF5 Check	21
BF-RL4 Transmitter Check	22
SS1-RL4 Probe Check	22
Problem Reporting	23
Appendix A: Technical Design Information	24
CE Certification	24
Radio Certification (EU)	24
Radio Link	24
Routine Servicing	24
Component Diagram	24
Radio Protocols	25
Diagnostic Information	26
Index	27

Introduction

The SunScan System Radio Link



The SunScan radio link is designed to give cable-free operation of the SunScan system in field use. It is no longer necessary to connect the SunScan probe to the reference Sunshine Sensor BF5 by what is sometimes a substantial length of cable (i.e. EXT/8w-xx cables).

The radio link can be used in low canopies (field crops, cereals, etc) and in tree canopies (orchards, tree nurseries, etc).

Handling and manipulating the cable within a crop has often been a laborious aspect of SunScan measurements. In addition, the BF5 sensor had to be relocated frequently. The advantages of the radio system are considerable:

- ◆ Cable handling and wear is avoided
- ◆ Sampling measurements can be taken much faster
- ◆ Distances over 100m from the BF5 sensor are possible
- ◆ Fewer BF5 relocations give quicker operation.

Achievable Range

The radio link works on a licence-free frequency in EU countries. The transmitter power is regulated by law, and this limits the clear line of sight range in good conditions to a maximum of about 250m.

The maximum achievable range in real field conditions, working within canopies, will be less than this. It will depend on the nature of the foliage in the canopy, and whether it is wet or not. In addition there may be local sources of electromagnetic RF interference that could reduce the achievable range.

Disclaimer! In practical use we do not guarantee any minimum range, or that the radio link can be used at all, in a particular situation. The radio link is an option. If it cannot be used, the alternative is to use the type EXT/8w-xx optional extension cables.

About this Manual

This manual describes only the radio link components for use with the SunScan Canopy analysis System, and it concentrates on the different procedures needed when the radio link is used instead of the normal (EXT/8w-xx) cable connection.

The radio link is supplied as part of a full SunScan Radio System. The system must include a Sunshine Sensor type BF5 (or the earlier BF2 or BF3 model).

The main components of the radio link are the transmitter module type BF-RL4, and the SunScan probe with built-in radio receiver type SS1-RL4.

Other Documents Required

The operation of the SunScan system, without using the radio link, is fully covered in the SunScan Canopy Analysis System User Manual. This will be referred to as the SunScan manual.

You will also need the User Manual for the Sunshine Sensor BF5 This will be referred to as the BF5 manual.

Upgrade Systems

Existing systems with BF5, BF2 or BF3 sensors can be returned to Delta-T for conversion to the radio link. The radio link cannot be used with the original BF1 Beam Fraction sensor.

If you have a BF2 or BF3 sensor, please interpret references to the BF5 in this document as applying to them. There are some differences but these should be obvious.



Unpacking

When unpacking the components for the first time, check that you have received the following items specific to the radio link.

Warning! If anything is damaged or missing, you must immediately notify the carriers. You may be unable to claim, if you delay. Also notify your distributor or Delta-T, with details of damage or missing items.

Components

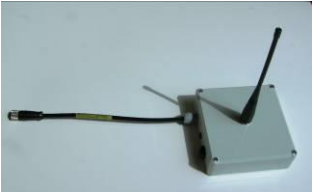
The SunScan Radio Link system comprises of a SunScan Probe SS1-RL4, the Transmitter module BF-RL4, and a pack containing the mounting plate and two removable antennas as illustrated below. This radio link user manual supplement is included.

Sales Code and description:	
SunScan Probe type SS1-RL4. The radio version is distinguished by the antenna connector and probe LED built into the handle.	 A white, handheld probe with a black antenna connector and a red LED on the handle. The SunScan logo is visible on the side.
Radio Module (transmitter) type BF-RL4 with aerial	 A rectangular, light-colored transmitter module with a black antenna connector and a black aerial.
Mounting plate and two identical antennas. The mounting plate fits on to the tripod for the BF5.	 A black mounting plate and two identical black antennas with silver tips.

Health and Safety Issues

The Radio Link works on a 434 MHz frequency, licence-free in the EU, and in some other countries world-wide. The transmitted power is restricted to 10mW.

Note: There are no known health and safety issues associated with the use of this frequency and power level.

There is no health hazard involved in touching the antennas while they are in use, but you should not do this because it may contravene the certified operating conditions.

There is no danger to the radio systems if they are operated without the antennas in place or properly connected. However, you should avoid doing this wherever possible.

Description

SunScan Probe

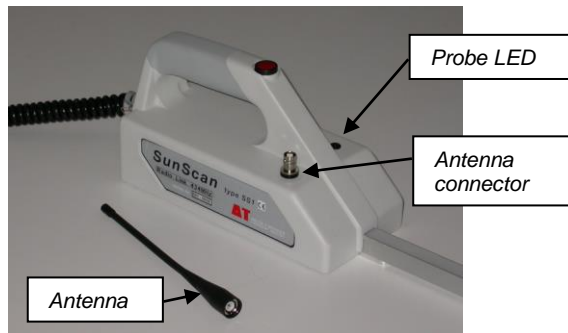

The radio link receiver circuit is built into the probe handle. When the radio system is in use, the probe LED indicates whether or not signals from the BF-RL4 radio transmitter are being picked up.

The radio receiver is powered from the same batteries that power the SunScan probe.

The handle can be dismantled from underneath to access the batteries and to replace a desiccant pack from time to time (see Routine Maintenance section).

Transmitter Module

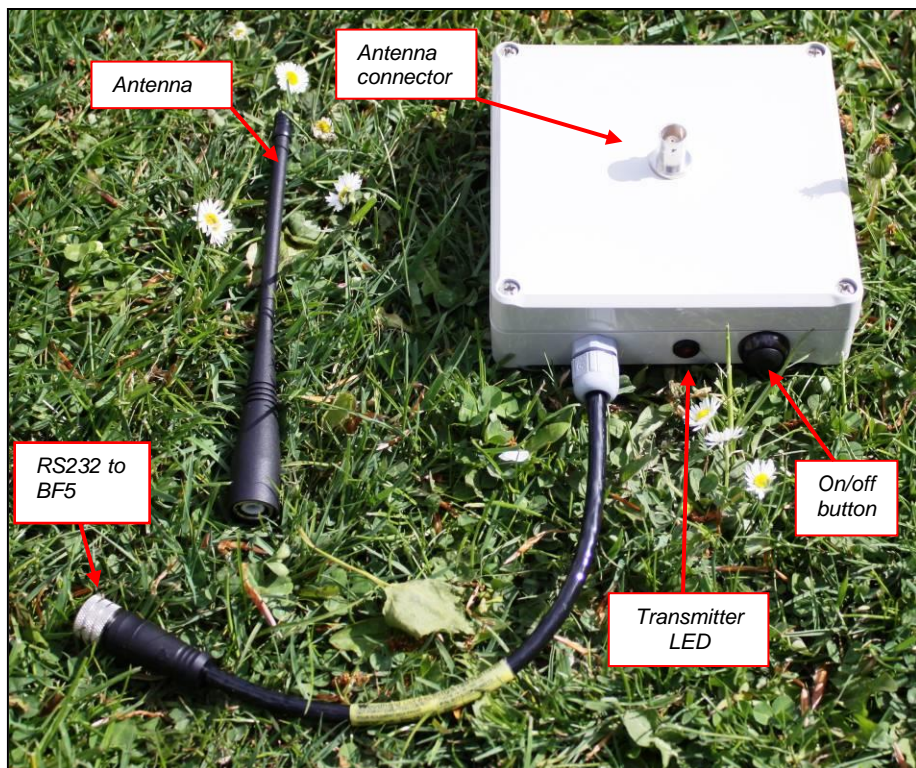

Getting Started

Familiarisation

If you are new to the SunScan system, then work through the SunScan manual to get the system going normally without using the radio link.

If you are already familiar with the functioning of the SunScan system it is better to confirm normal operation with the BF5 to SunScan cable EXT/8w-05 first, then proceed through the steps below.

Preliminary Checks

Transmitter Module and BF5

Fit the BF-RL4 transmitter module on to the mounting plate next to BF5, and mount them both on to the tripod.

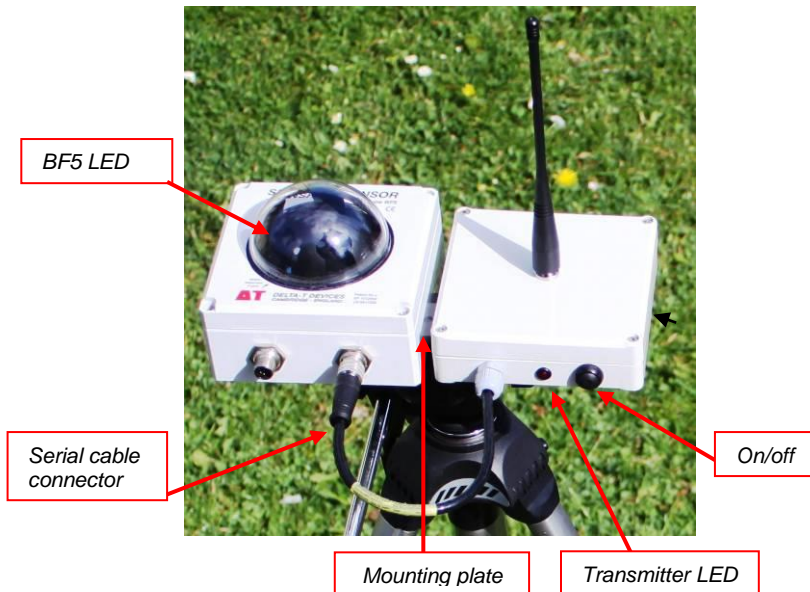

- ◆ Connect the transmitter cable to the BF5 serial connector. If you were using the system without radio, disconnect the BF5 to SunScan cable from both the BF5 and the SunScan probe.
- ◆ Connect the antenna. Make sure there is no chance of its shadow falling on the BF5 dome when it is positioned in the field.

- ◆ Depress the on/off button on the transmitter to start. You will see the transmitter LED flash every 3 seconds.
- ◆ When the transmitter is on and connected to the BF5, you will see the BF5 LED flash synchronously with the transmitter every 3 seconds. A double flash on the transmitter indicates it is receiving RS232 data from the BF5.

SunScan Probe

- ◆ Connect the SunScan probe coiled cable to the Recon PDA.
- ◆ Disconnect the EXT/8w-05 cable from the probe handle, if you haven't already done so.
- ◆ Connect the antenna to the BNC connector on the SunScan handle. Keep the SunScan probe horizontal. The antennas on both the probe and the BF-RL4 module should be approximately vertical.
- ◆ Run the SunData program in the PDA

SunScan will report version number "v1.02R" in SunData opening screen.

The receiver will start listening *after* you take a reading, so the first reading may be bad (showing the incident PAR approximately zero).

You will see the LED on the SunScan light up continuously while it searches for a transmission. Once it has found one, it will give a double flash each time it gets an updated reading (every 3s).

If it loses the signal for any reason (e.g. out of range, or transmitter switched off), you will see a few short single flashes, followed by a long search, and then if there is still no signal, it sleeps. It will continue listening for about 15 minutes after a reading, so you should have good values *after* the very first reading, unless you take a long break.

Testing the Range

Having established correct operation at close quarters, now extend the distance between the BF5 and the probe to check the system remains in contact.

If you have the space, go to about 50m range. Mount the BF5 normally at least 1.5 m above ground level. Hold the SunScan probe horizontally at a similar height. Remember that the antennas on both the probe and the BF5 must be able to "see" each other. Keep your body out of the line of sight. Check that the probe continues to show its double flash.

By experimenting further, with greater distance or with intervening vegetation, you will establish when the system can no longer make contact.

If you lower the probe to ground level, at range, you may start to lose the signal. This is a normal ground effect. Some suggestions on how to work around this effect are given in the Field Techniques section.

The above tests will establish if the radio link is working. If you have problems getting this far, please consult the Troubleshooting section.

Field Techniques

Measurement Procedures

Initial Considerations

Having established that radio system works in the lab, take the SunScan system to the field measurement site.

- ◆ Include the EXT/8w-xx extensions cables in your equipment. You may need it as an alternative if radio link operation is not viable, and you will need it if you want to operate the SunScan “Recalibrate” function.

Locating the BF5 Sensor

- ◆ Mount the combined BF5 sensor and BF-RL4 on its tripod above the canopy, and ensure that it is level. The BF5 is not orientation sensitive but make sure the shadow of the BF-RL4 antenna does not fall across the dome at any time.
- ◆ Start your measurements close to the BF5.
- ◆ If the field terrain is not level, consider the best location to give good line of sight to all parts of the crop within a range of about 100-200m. This will minimise the number of times you have to move the BF5 to a new location.

Field Calibration Check

Note: The “Recalibrate” function is deliberately disabled when the radio link is in operation.

It is good practice to start any set of measurements with a calibration check briefly described here (**Utilities, Calibrate, Recalibrate SunScan** - see the SunScan manual for full details). Do these before you set up the radio link.

- ◆ Connect the SunScan system normally with the EXT/8w-05 cable.
- ◆ Hold the SunScan horizontally at the same height as the BF5 and close to it, in the same uniform light. The PAR readings for the probe and the Total PAR should be within 5-10% of each other. Only use the Recalibrate function if you need to.
- ◆ After this check, convert the system to radio link operation and proceed with canopy sampling measurements.

Optimising the Range

Two effects determine the achievable range on any given day:

- 1) the weather and the light
- 2) the properties of the foliage within the canopy.

Changeable Light Levels

For the SunScan LAI estimates to work correctly, the BF5 must register the incident light levels at the location of *the SunScan probe*.

In some weather conditions (e.g. fast moving cloud shadows) this will no longer be true if you move too far away from the BF5. So you should:

- ◆ Stay closer to the BF5 and relocate it more frequently.
- ◆ Check the local incident light level by holding the probe above the canopy. If it is significantly different from the BF5 Total reading, then wait until the light conditions of both have equalised again.
- ◆ Bear in mind that the BF5 signal is read up to 3 seconds before the probe reading is made.

The State of the Canopy

The radio signal strength reaching the bottom of the canopy is reduced by the density and wetness of the foliage and by proximity to the ground surface.

- ◆ After you receive the signal with the probe above the canopy (double flashes), move the probe below the canopy as quickly as possible to take the transmitted reading.
- ◆ Then bring the probe above the canopy again, and wait until the double flash shows again before taking the next reading.

Even if the probe immediately indicates the loss of the signal (single flash) below the canopy, it will retain and use the previous BF5 reference readings. You have about 15 seconds in which to do this, but don't delay.

Trees and Tall Canopies

A tall canopy is one in which you cannot easily hold the probe above the canopy to take measurements. This will mean you cannot use some of the techniques described above, and you may have to be content with a more restricted range of operation.

The location of the BF5 above the canopy may present problems too. However, for low tree canopies such as orchards and tree nurseries, an extended tripod or a monopod can be effective.

- ◆ Check the levelling of the BF5 in these circumstances. This may not be so easy, but do it as well as you can.
- ◆ Restrict your measurements to the time of day when the sun is near zenith. This will minimise levelling errors of the BF5.

Tall tree canopies, like forests, present different challenges.

- ◆ Mount the BF5 above the canopy on a tower, if you have one.
- ◆ Find a clearing or somewhere else well away from tree shadows and shading.

When taking measurements beneath the trees, you may be distant from the BF5 and you cannot check the incident light above the canopy at your location.

- ◆ Choose weather with slowly changing light levels. Clear blue skies with a high sun or complete overcast conditions are best.

Warning! Whatever canopies you are working in, always remember that for LAI theory to be valid, canopy must be uniform and randomly distributed. In many situations, this will obviously not be the case. However, PAR readings will be valid, and the LAI estimates may have comparative value if used carefully.

Technical Reference

Specifications

Radio Link Performance

Range	Up to 250m line of sight. Less within a canopy.
Frequency	434 MHz. License exempt in EU and some other countries world-wide.
Operating Temperature	0-60°C

Range Disclaimer

In practical use, we do not guarantee any minimum range, or that the radio link can be used at all, in any particular situation. The radio link is an option. If it cannot be used, the alternative is to use one or more EXT/8w-xx cables, of which the EXT/8w-05 remains an essential part of a full SunScan system

SunScan Transmitter Module type BF-RL4

Transmitted power	10mW maximum
Antenna	¼ wave whip; BNC connector
Internal battery	4 x 1.5V AA Alkaline batteries
Battery lifetime	500-1000 hours operating time
Environmental: Sealing	IP65 (shower and dust proof)
Desiccant pack	Activated clay, 60 x 130 mm
RS232 connector	DB9 female, cable mounted
Mounting bush	¼ inch Whitworth camera tripod socket
Size and weight	125mm x 125mm x 40mm; 450g (excl. antenna)

SunScan Radio Probe type SS1-RL4

These specifications are additional to those in the SunScan User Manual.

Antenna	¼ wave whip; BNC connector
Internal battery	4 x 1.5V AA Alkaline (probe) batteries
Battery lifetime	About 500 hours to 5000mV endpoint.
Environmental: Sealing	IP65 (shower and dust proof)
Desiccant pack	Activated clay, 60 x 130 mm

Tripod Mounting Plate for BF5 and BF-RL4

Dimensions	170mm x 40mm x 5mm Anodised aluminium
Central tripod hole	¼ inch Whitworth camera tripod socket
BF5 and BF-RL4 mounts	2 x ¼ inch Whitworth camera screws

Routine Maintenance

Batteries

The components of the SunScan Radio system are all powered by alkaline 1.5V AA cells (apart from the PDA). Do not substitute other types of cell.

- ◆ Always check battery levels before using the equipment.
- ◆ Replace SunScan system batteries on a 6 to 12-month cycle. Different components can exhaust their batteries at different rates.
- ◆ Check the rechargeable Recon PDA NiMH battery daily in use.

Warning! Do not leave the equipment with exhausted batteries in place, in case they leak.

SunScan Transmitter module BF-RL4

The transmitter is powered by 4 x AA cells. These should give 500 – 1000 hrs operating time. To check the battery:

- ◆ Depress the on/off button. After a few seconds the red LED will flash at 3-second intervals.
- ◆ If no flash occurs, undo the four case screws, and fit or replace the 4 alkaline AA cells in the battery holder.
- ◆ For an indication of the remaining battery life, you will need a voltmeter. Open the case, and measure the battery voltage with the transmitter module powered.
- ◆ Replace the batteries when the voltage nears the recommended end point of 5V.

SunScan Probe SS1-RL4

The probe is powered by 4 x AA cells. These should give about 500 hrs operating time with radio usage. The SunScan Probe battery check procedure is briefly described here (see the SunScan manual for full details).

- ◆ Connect the probe to the PDA, run the SunData program and take a reading with the probe. Any light level will do, Then tap **Utilities,>About** to display the battery reading in millivolts, plus various version numbers

- ◆ Replace the batteries when the level has fallen near to 5000mV (the 4700 mV level only applies to non-radio operation).

To replace the probe batteries (or check them with a voltmeter), dismantle the probe handle.

- ◆ Undo the base plate by removing four cross-head corner screws. Remove the handle carefully whilst supporting the probe.

Sunshine Sensor BF5

The BF5 is powered by 2 x AA cells. These should give typically about one year's lifetime. (The BF5 battery check is fully detailed in the BF5 manual.)

To check the battery voltage:

- ◆ Run **BF5Read** in your PC and communicate with the BF5 through its RS232 cable. The battery voltage is reported.
- ◆ Alternatively, open the BF5 case (undo the four corner screws) and measure the BF5 battery voltage with a voltmeter.
- ◆ Replace the batteries when their voltage drops to near 4500 mV.

Recon PDA

The Standard Recon PDA contain a rechargeable NiMH battery.

To check the battery level:

- ◆ Switch on the PDA
- ◆ Tap **Start, Settings, System, Power** to see the state of the battery.

Note: An AA Power Boot module is available for the Recon PDA, taking 2 AA lithium or Alkaline batteries. Contact Delta-T for further details.

Desiccant

The SunScan probe, BF5 and BF-RL4 transmitter module each contain desiccant packs. The desiccant packs must be refreshed from time to time to avoid the possibility of condensation within the instruments.

The dryness of the desiccant pack is indicated by a coloured panel on the BF5 and SunScan, but not on the BF-RL4. Blue indicates dry, pink indicates that renewal is needed. In any case it is good practice to exchange the desiccant pack for a fresh one whenever the instrument case is opened - for example when replacing the batteries.

To regenerate the desiccant

The desiccant pack can be regenerated by heating. Heat the pack in an oven for a few hours at about 140°C. Allow it to cool down away from moisture before reinstalling it in the equipment.

Warranty and Service

Terms and Conditions of Sale

Our Conditions of Sale (ref: COND: 1/07) set out Delta-T's legal obligations on these matters. The following paragraphs summarise Delta T's position but reference should always be made to the exact terms of our Conditions of Sale, which will prevail over the following explanation.

Delta-T warrants that the goods will be free from defects arising out of the materials used or poor workmanship for a period of twelve months from the date of delivery.

Delta-T shall be under no liability in respect of any defect arising from fair wear and tear, and the warranty does not cover damage through misuse or inexpert servicing, or other circumstances beyond their control.

If the buyer experiences problems with the goods they shall notify Delta-T (or Delta-T's local distributor) as soon as they become aware of such problem.

Delta-T may rectify the problem by replacing faulty parts free of charge, or by repairing the goods free of charge at Delta-T's premises in the UK during the warranty period.

If Delta-T requires that goods under warranty be returned to them from overseas for repair, Delta-T shall not be liable for the cost of carriage or for customs clearance in respect of such goods. However, Delta-T requires that such returns are discussed with them in advance and may at their discretion waive these charges.

Delta-T shall not be liable to supply products free of charge or repair any goods where the products or goods in question have been discontinued or have become obsolete, although Delta-T will endeavour to remedy the buyer's problem.

Delta-T shall not be liable to the buyer for any consequential loss, damage or compensation whatsoever (whether caused by the negligence of the Delta-T, their employees or distributors or otherwise) which arise from the supply of the goods and/or services, or their use or resale by the buyer.

Delta-T shall not be liable to the buyer by reason of any delay or failure to perform their obligations in relation to the goods and/or services if the delay or failure was due to any cause beyond the Delta-T's reasonable control.

Service and Spares

Users in countries that have a Delta-T distributor or technical representative should contact them in the first instance.

Spare parts for our own instruments can be supplied and can normally be despatched within a few working days of receiving an order.

Spare parts and accessories for products not manufactured by Delta-T may have to be obtained from our supplier, and a certain amount of additional delay is inevitable.

No goods or equipment should be returned to Delta-T without first obtaining the return authorisation from Delta-T or our distributor.

On receipt of the goods at Delta-T you will be given a reference number. Always refer to this reference number in any subsequent correspondence. The goods will be inspected and you will be informed of the likely cost and delay.

We normally expect to complete repairs within one or two weeks of receiving the equipment. However, if the equipment has to be forwarded to our original supplier for specialist repairs or recalibration, additional delays of a few weeks may be expected. For contact details see below.

Technical Support

Users in countries that have a Delta-T distributor or technical representative should contact them in the first instance.

Technical Support is available on Delta-T products and systems. Your initial enquiry will be acknowledged immediately with a reference number. Make sure to quote the reference number subsequently so that we can easily trace any earlier correspondence.

In your enquiry, always quote instrument serial numbers, software version numbers, and the approximate date and source of purchase where these are relevant.

Contact Details:

Tech Support Team
Delta-T Devices Ltd
130 Low Road, Burwell, Cambridge CB25 0EJ, U.K.
email: tech.support@delta-t.co.uk
email: repairs@delta-t.co.uk
Web: www.delta-t.co.uk
Tel: +44 (0) 1638 742922
Fax: +44 (0) 1638 743155

Troubleshooting

Procedure

Always try to isolate the source of the difficulty.

Does the SunScan system work in the normal way without the radio link, using the BF5-SS1-05 cable?

If not, the problem is with the SunScan system. Consult the SunScan system and the Sunshine Sensor BF5 manuals for troubleshooting advice.

If so, the problem is confined to the radio link operation, please consult the sections below.

BF5 Check

This is a quick check for the BF5 only using the SunRead PC software. The BF5 does not have any radio components in it, but is useful for verifying the operation of other components.

- ◆ Disconnect any EXT/8w-xx cable.
- ◆ Connect the BF5 to a PC running SunRead, with the RS232 cable (DCT-COM) via a COM port. This will interrogate the BF5 at 3-second intervals and give real-time readings for Total and Diffuse light levels.
- ◆ Expose the BF5 dome to a source of bright light – preferably daylight.

Check that:

- ◆ The light units are set to PAR
- ◆ The real-time values of Total and Diffuse PAR are sensible.
- ◆ The stated battery level indication is ok.

If any of these are not correct, open the BF5 to check batteries and inspect for any hardware problems or faults.

BF-RL4 Transmitter Check

- ◆ Connect the BF-RL4 to a tested BF5 (without a EXT/8w-xx cable).
- ◆ Check the BF-RL4 antenna is correctly plugged in to the BNC connector.
- ◆ Depress the button to switch on. The BF-RL4 red LED should flash at intervals of 3 seconds.

Symptom	Cause or comment
BF-RL4 LED fails to flash	Check that the on/off button is latched in the depressed (on) position. Check the batteries and the battery pack connector. Check that the internal LED PCB connector is in place.
BF-RL4 gives single flashes, but BF5 LED fails to flash	Check the RS232 cable and D-connector and its internal connections in the BF-RL4 module.
BF-RL4 gives double flashes	Normal operation with working BF5 connected to the BF-RL4. The double flash indicates that the BF-RL4 is receiving a valid RS232 stream from the BF5.

SS1-RL4 Probe Check

First check the normal operation of the SS1-RL4 probe connected to a PDA, using the EXT/8w-05 cable and a pre-tested BF5.

Then:

- ◆ Disconnect the EXT/8w-05 cable.
- ◆ Fit the radio antenna to the BNC connector on the probe handle.
- ◆ Operate the pre-tested BF-RL4 connected to the BF5, at close range (up to 5m distance) preferably in daylight conditions.
- ◆ If indoors, make sure both the probe and the BF5 are exposed to a source of bright light.
- ◆ Check for the correct operation of the indicator LEDs on the BF-RL4 and the BF5.
- ◆ With the PDA display set for PAR readings, take some occasional readings at half-minute intervals and observe the activity of the probe LED.

After a few single flashes, the probe should “lock on” to the transmitted radio signal and simultaneously give a double flash.

Observe the magnitude of the PAR light readings displayed on the PDA.

Symptom	Cause or comment
Probe LED gives single long flash only. No double flash.	Failed to find a transmission. Repeat the antenna connection checks on both probe and transmitter.
Probe was locked on, but then gives single short flashes followed by a long flash.	Normal search mode indication. The transmitted signal has stopped, or become too weak to be received.
Probe LED fails to flash.	Radio link receiver circuit in probe is suspect. Dismantle the handle and inspect for obvious hardware faults
Probe is locked on, but first reading shows Total and Diffuse PAR values of 0.2 μmol	The very first reading under radio link operation is near zero. Subsequent readings will be correct for the light exposure.
Probe disconnected from PDA, but probe LED remains on.	Normal operation. The probe receiver stays listening on the radio link for 15 minutes. Turn off the transmitter after use.
"SunScan probe not connected" or "communication error" messages are frequent	Check the probe batteries. Possible environmental RF interference so move to a different location.

Problem Reporting

If you still have problems, and need to contact your distributor or Delta-T, it will help considerably if you can mention as many relevant details as possible. In particular:

- ◆ A description of the fault, its symptoms, or error messages
- ◆ What components of the SunScan system you are using
- ◆ Details of any PC you are using
- ◆ Software version numbers and hardware serial numbers.

Appendix A: Technical Design Information

CE Certification

For a copy of EMC compliance certificates contact Delta-T at www.delta-t.co.uk or e-mail: tech.support@delta-t.co.uk

Radio Certification (EU)

For a copy of EU radio compliance certificates contact Delta-T at www.delta-t.co.uk or e-mail: tech.support@delta-t.co.uk

Radio Link

Routine Servicing

The radio frequency components of the SunScan radio link are stable and do not require any routine attention. No provision is made for user adjustment.

The following notes may be of assistance with troubleshooting, if radio link problems are encountered.

Component Diagram

The circuit shown below is from the transmitter module. The receiver circuit in the probe handle is similar.

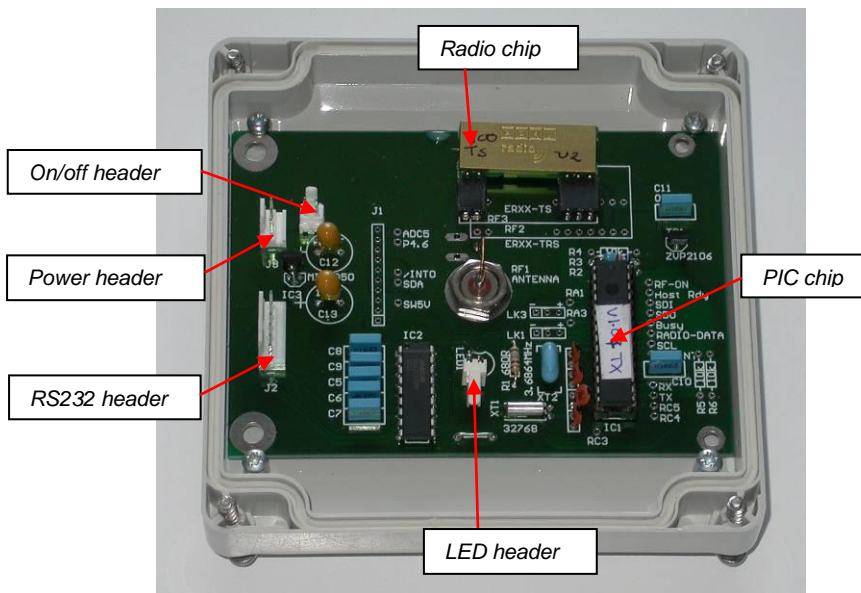

Radio Protocols

When the BF5 radio link is switched on, it resets the Easy-Radio transmitter module to its default values, and then transmits the software version number. Thereafter it transmits values of Total and Diffuse light every 3s.

When a SunScan reading is taken, the SunScan first measures the signal on the analogue connector (BF2, BF3 or BF5, connected via cable). If this signal is less than $10 \mu\text{mol m}^{-2} \text{s}^{-1}$, it assumes no BF5 is connected, and gets the values from the radio link instead. With no BF5 connected, the SunScan normally measures zero, though there may be occasional noise in this reading.

The radio receiver is normally in a sleep state. It is woken by a data request from the SunScan, and sends a reading if it has a valid one, or zero otherwise. It then searches for the transmission, powering up for 10 seconds, waiting for 3 seconds, for up to a minute. If a transmission is found, it is decoded, and the values stored ready to pass on to the SunScan. Once a valid transmission has been found, the radio link will remain synchronised to it, waking up every 3s to receive the next transmission.

Timeouts

The radio link will return zero Total and Diffuse values if it does not have a valid reading. A valid reading is kept for up to 15s. This allows for occasional reception failures. The radio link will continue to receive radio transmissions for 15 minutes after the last SunScan data request, after which it will return to sleep. It will sleep sooner if there is no signal

received, or the signal cannot be decoded. If a valid reading has not been received for 15s, the radio link will return zeros, and start searching for a signal again.

This means that the first reading a user makes after a break will return approximately zero Total and Diffuse light readings. The next readings will normally then be valid, and will remain so as long as the receiver is within range and readings are made within 15 minutes of the previous one. If the transmission stops or fails for some reason, the last valid reading will be used for another 15s, then zero returned again.

Data Source

The SunScan will get Total and Diffuse values from the radio link if the measured value for Total from the analogue socket is less than $10 \mu\text{mol m}^{-2} \text{s}^{-1}$.

If a BF2, BF3 or BF5 is connected to the analogue socket, this will always be used as long as the Total light value is $>10 \mu\text{mol m}^{-2} \text{s}^{-1}$. If the BF5 is being used, and there is no radio link fitted, or a link is fitted but there is no valid signal, then any light level below $10 \mu\text{mol m}^{-2} \text{s}^{-1}$ will be returned as zero. This will not be a problem in normal use, but might be noticed in very low light levels, e.g. inside.

Conversely, if the radio link is fitted, and the analogue socket is full of dirt, it is possible for the inputs to float above $10 \mu\text{mol m}^{-2} \text{s}^{-1}$, disabling the radio receiver and giving false readings.

Diagnostic Information

Diagnostic information is available from the SunData **Comms Test** screen. Type **TT** to enter **TEST:** mode, then **L**

The SunScan will now relay the receiver software version, and give a running commentary on what it is doing, which can be useful for debugging and faultfinding. See a sample session below. Switch the transmitter on just before the TEST:L command to see the transmitter version no.

```
II>v1.02R (C) JGW 2004/01/19                               SunScan software version no.

TT>TEST:Lv1.00RX (C)JGW 08-MAR-4                           receiver software version no.
ER_CMD#Rlno signal                                         ER_CMD#Rl resets the radio module
ER_CMD#Rlv1.00TX (C)JGW 05-MAR-4                           transmitter software version no.

bad data sig 003
ER_CMD#Rl0018,0004,0 sig 004                               Total, Diffuse, Sunshine from BF5
0018,0004,0 sig 003                                       Sig is rough signal strength
0018,0004,0 sig 004                                       Sig 000 is max signal
0018,0004,0 sig 003                                       Sig 040 is minimum receivable
0018,0004,0 sig 003

no signal                                                 transmitter switched off
no signal
no signal
no signal
no signal
no signal
no signal
re-sync
ER_CMD#Rlno signal                                         10s searches
ER_CMD#Rlno signal
ER_CMD#Rlno signal

Sleep                                                     receiver now powered down
```

Index

A

Antenna 7, 8, 10, 11, 13, 16, 22, 23

B

Batteries 8, 9, 16, 17, 18, 21, 22, 23
alkaline 17
life 16, 17
BF2 2, 6, 25, 26
BF3 dome 10, 21
BF5-SS1-05
cable 5

C

Calibration 13
Canopy 6, 13, 14, 15, 16
CE Conformity 2, 24

D

D-connector 11, 22
Debugging 26
Desiccant 8, 9, 18
regenerate 18
Disclaimer 6, 16

E

Environmental 16
EXT/8w-xx
cable 5

F

Familiarisation 10
Foliage 6, 14
Frequency 6, 8, 24

H

Health and Safety 8

I

Incident light 14, 15

L

LAI 14, 15

M

Maintenance 8, 9, 17
Mounting plate 7, 10

O

On/off button 9, 11, 17, 22
Out of range 11

P

PDA 18, 22, 23
Preliminary Checks 10
Probe handle 8, 11, 18, 22, 24
Probe LED 23

R

Radiation
PAR 11, 13, 15, 21, 22, 23
Total and Diffuse 13, 14, 21, 23, 25,
26
Radio
Certification 24
Radio Link 1, 5, 7, 8, 16, 24
Range 6, 11, 14, 16
Recalibrate 13
Receiver 6, 8, 11, 23, 24, 25, 26

Relocating the BF3 5
RS232 cable 18, 21, 22

S

Service and Spares 20
Signal 11, 14, 22, 23, 25, 26
Sleep state 25
Specifications 16
SunData software 11, 17, 26
SunScan Probe 1, 6, 7, 8, 11, 16, 17,
22
Sunshine Sensor 2, 5, 6, 18, 21

T

Technical Support 20
Transmitter module 6, 7, 8, 9, 10, 11,
17, 18, 23, 24, 25, 26

Trees 14
Troubleshooting 12, 21

U

Unpacking 7
Upgrade 6

V

Voltmeter 17, 18

W

Warning 7, 15, 17
Warranty and Service 19